

CLARKE®

ADJUSTABLE MACHINE TOOL STAND

MODEL NUMBER: CAMTS

PART NUMBER: 6501610

INTRODUCTION

Thank you for purchasing this CLARKE Adjustable Machine Tool Stand.

Before attempting to use this product, please read this manual thoroughly and follow the instructions carefully. In doing so you will ensure the safety of yourself and that of others around you, and you can look forward to your purchase giving you long and satisfactory service.

GUARANTEE

This product is guaranteed against faulty manufacture for a period of 12 months from the date of purchase. Please keep your receipt which will be required as proof of purchase.

This guarantee is invalid if the product is found to have been abused or tampered with in any way, or not used for the purpose for which it was intended.

Faulty goods should be returned to their place of purchase, no product can be returned to us without prior permission.

This guarantee does not effect your statutory rights.

PART IDENTIFICATION

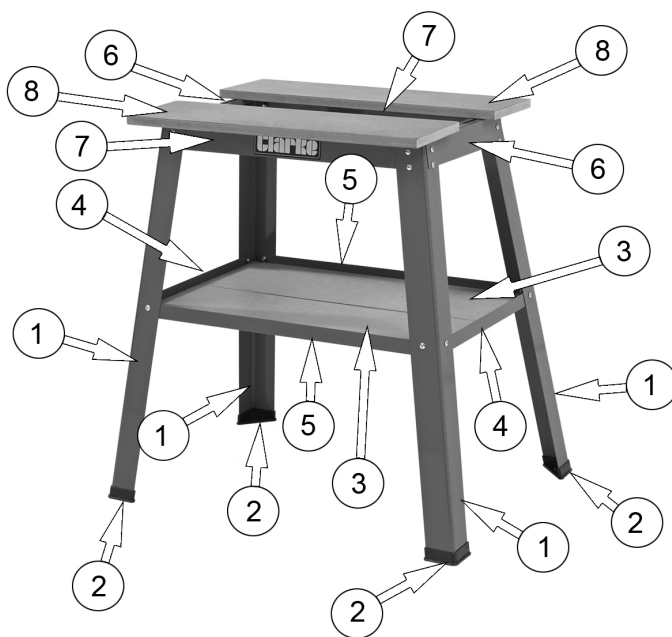

NO	DESCRIPTION	QTY
1	Legs	4
2	Foot	4
3	Shelf	2
4	Short Shelf Support	2
5	Long Shelf Support	2
6	Short Spreader Bar	2
7	Long Spreader Bar	2
8	Top Panel	2
FIXINGS SUPPLIED		
	Wood Screws	8
	Washers	8
	Bolts	24
	Spring Washers	24
	Nut	24

If any parts are missing or damaged, please contact the Clarke dealer where you purchased the tool stand.

ASSEMBLY

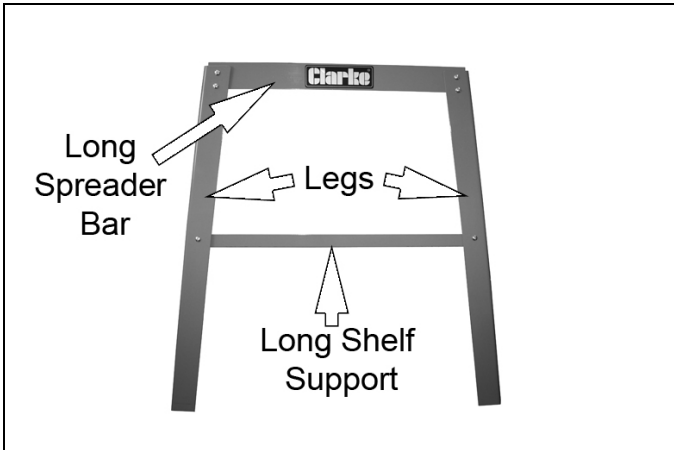

1. Make up the front frame by connecting the two legs, a long spreader bar, and the long shelf support as shown. Fix them together using the bolts, nuts and spring washers.
 - The nut and spring washer should be on the inside of the completed frame
 - Do not fully tighten the nuts and bolts at this stage.
2. Make up the rear frame in the same way.

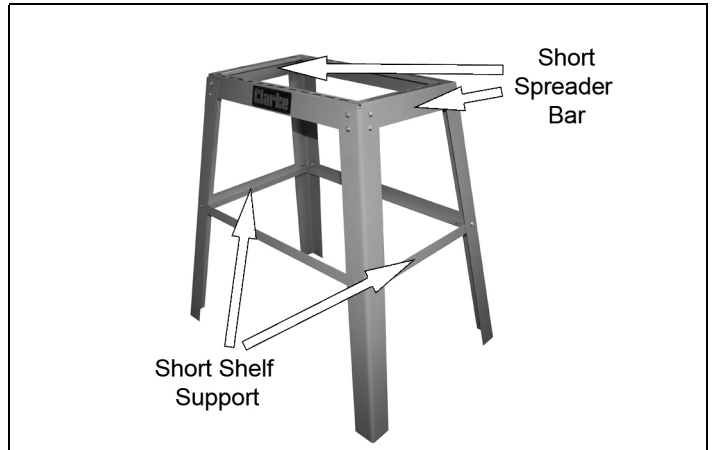

3. Join the two frames using the two short shelf supports and two short spreader bars, again fixing them together using the bolts, nuts and spring washers.



4. Place the two shelves into position.
5. Fit the feet to the end of each leg.



6. Place the the top panels on to the short spreader bars as shown, set to the required distance apart and fix in position using the screws and washers supplied.
 - The screws are inserted from below through the short spreader bars into the top panels.
7. Tighten up all the nuts, bolts and screws. The tool stand is now ready for use.

SPECIFICATIONS

Model Number	CAMTS
Maximum Load	226 kg
Weight (unpacked)	11.5 kg
Dimensions (L x W x H)	810 mm x 570 mm x 810 mm